

## Scanning Stage SCAN<sup>plus</sup> 200 x 200 for Upright Microscopes

### Specifications

Travel range	max. 200 x 200 mm
Max. travel speed	max. 240 mm/s (with 4 mm ball screw pitch)
Repeatability	< 1 µm (bi-directional, measured according to VDI/DGQ 3441)
Accuracy	+/- 1 µm (measured according to VDI/DGQ 3441)
Resolution	0.05 µm (smallest step size)
Orthogonality	< 10 arcsec
Motor	2-phase stepper motor
Limit switches	Hall sensors
Material / surface	aluminium / anodic coating, black lacquered
Weight	approx. 8.9 kg

### Order Information

Order No.: 00-24-832-0000  
(4 mm ball screw pitch)

### Product Features

- ▶ flat, ergonomic design with rounded corners
- ▶ integrated linear measuring systems for highest accuracy
- ▶ for reflected and transmitted light applications
- ▶ L-shaped support stages optional available
- ▶ integrated electronic stage identification device ETS for automatic identification of the scanning stage and parametrization of the controller
- ▶ **5 years guarantee**, if the scanning stage is operated in the system with the Märzhäuser TANGO controller

### Dimensions

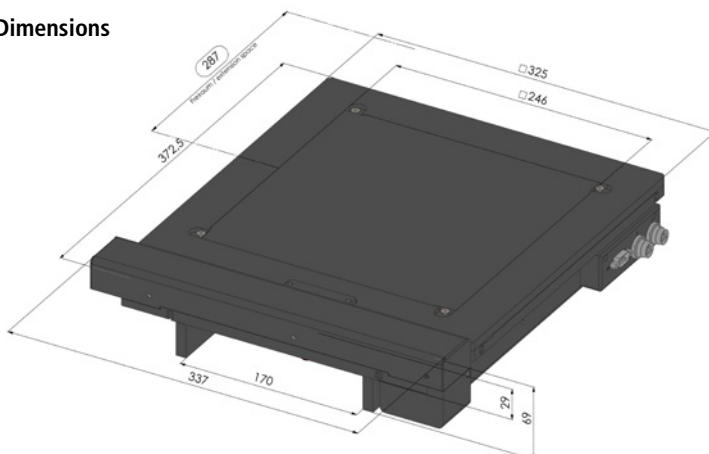

### Accessories

Metall plate (included in delivery)  
Order No.: 00-24-801-0011

For further accessories please visit:  
[www.marzhauser.com](http://www.marzhauser.com)